

Commercial generator set Hydraulic Series HG 20000



Cummins Onan

Performance you rely on.™



Features and Benefits

- Can start and run generator set anytime the vehicle engine is operating
- Cummins Onan custom engineered hydraulic generator set system
- High motor starting capability
- Meets NFPA 120° F (49° C) ambient* standard
- Single side serviceability
- 100% stainless steel housing/multiple air inlets (4)
- Four-point vibration isolated mounting system
- Closed loop hydraulic circuit for maximum hydraulic efficiency
- Electronic speed control
- Five year, 1000 hour limited warranty

Weight, size and sound level

Weight: Total 679 lb (309 kg)
 - Generator set 532 lb (241 kg)
 - Pump 124 lb (56 kg)
 - Reservoir 13 lb (6 kg)

Size: Length 44.4 in (1133 mm), width 19.3 in (490 mm), height 17.3 in (439 mm)



Digital display included

Models and ratings

Model	Shaft	Hz	Watts	Voltage	Amps	PF	Phase
20RBAA-3576	Keyed	60	20000	120/240	166/83	1.0	1

- All 60 Hz models operate at 1800 r/min.

* Cummins Onan tested for operation with cooling air inlet temperature up to 120° F (49° C). Ambient is defined as the air temperature measured at the cooling air inlet to the set

Standard features

- Hydraulic components:
 - Variable displacement piston pump
 - Piston motor drive
 - Automatic frequency adjust
 - Speed controller - power off: Rotor not turning, power on: rotor turning
 - Hydraulic oil heat exchanger
- Generator set housing:
 - Stainless steel
 - Single side serviceability
 - Multiple air inlet locations (4)
 - Single side interface for all hook-ups
 - Installs without removing housing
 - Four-point vibration isolated mounting system
 - Brushless alternator
- Generator set output:
 - 120/240 single phase, 4-lead
 - 10 ft power leads in non-metallic conduit
 - Power switch control, both mechanical and electrical
 - Power off position does not allow generator set to spin
 - Stable frequency
 - Circuit breakers (OEM/distributor supplied)
 - Capped voltage regulator
 - Factory load tested.
- Controls and displays:
 - Cummins Onan display by FRC with 15 ft harness; displays Hz, volt, amps, oil temperature and hours
 - On/off switch for generator set power and rotation
 - Solid state voltage regulation
 - Electronic speed control to maintain generator set frequency
- Reservoir:
 - 3 Gal hydraulic tank with integral filter
 - Filter with element condition indicator gauge, breather, and fill port
 - Mounting tabs for universal mounting
- Accessories:
 - Side discharge duct kit (P/N 541-1012)
 - Extension harnesses (see Operation and Installation manual)

Alternator details

Design: Cummins Onan AC, brushless, self-excited revolving field, permanently aligned to hydraulic motor by a splined shaft

Cooling: Direct drive blower wheel

Rotor: Laminated electrical steel assembly press-fitted to shaft, balanced; heavy insulated, Class 200 copper wire windings, optimized air gap for improved wave form and motor starting

Stator: Laminated electrical steel assembly, skewed for improved waveform; heavy insulated, Class 200 copper wire windings

Bearing: Double-sealed pre-lubricated ball bearing

Exciter: Solid state regulator and bridge rectifier supply field current

Hydraulic details

Cooling:

- High efficiency forward-inclined blade, plug fan
- Pressurized box with distribution volutes for optimum air velocity across heat exchanger
- Furnace brazed blades, 4 brace rods and epoxy powder coated for best fan durability
- Flow through heat exchanger 5-17 Gal/min (pump speed dependent)

Hydraulic power:

- Pump Pressure at full load 3500 psi.
- Operating flow and pressure 23 Gal/min, 3500 psi (full load)
- Pump - 90 cc, variable displacement piston pump SAE C flange 1.5 in diameter with 3/8 in key shaft (no spline shaft option)
- Motor - fixed displacement piston motor
- Required pump speed 1150-3900 r/min maximum
- Requires 43.2 hp from drive engine at full load
- Fluid Dexron III - 6 Gal – total

Generator set performance

Frequency regulation	No load/Full load	+/- 0.5%
Voltage regulation	No load/Full load	+/- 2%

Frequency variation	Constant load	+/- 0.5%
Voltage variation	Constant load	+/- 0.5%

Basic dimensions

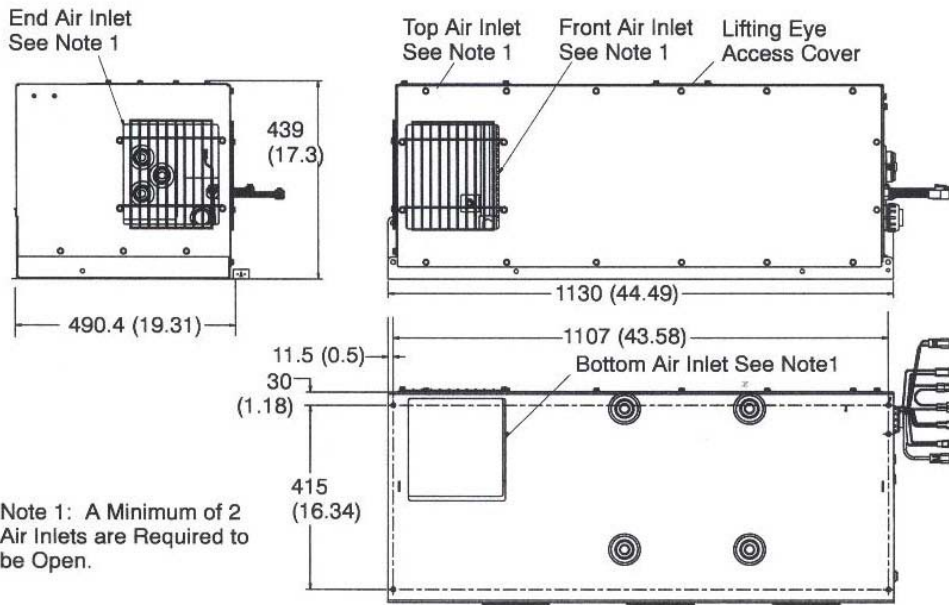

90cc Pump

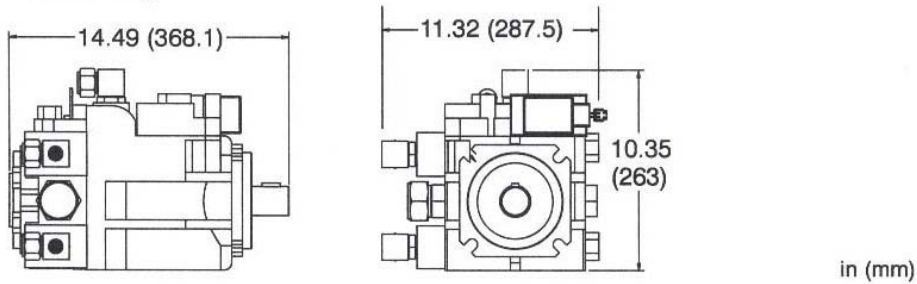

Note: This outline drawing is provided for general reference only and is not intended for design or installation. For more information see Operation and Installation manuals or obtain drawing 500-3763 and wiring diagram from your distributor/dealer.

Hydraulic operational schematic

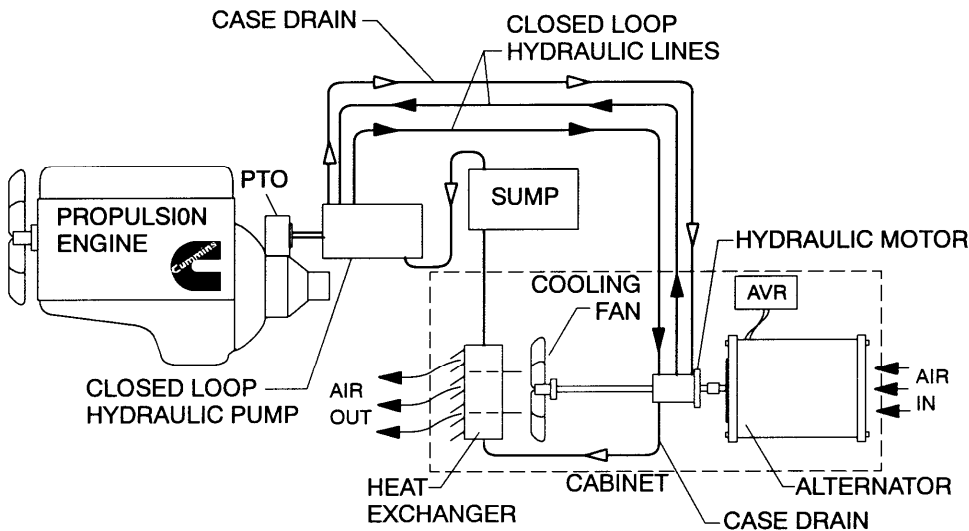

Standards and testing

- Tested at extremes of temperature -20° F (-29° C) to 120° F (49° C) for starting and operation
- Tested installed
- Tested with commercial loads
- Field test program
- This generator set was designed and manufactured in facilities certified to ISO 9001
- CSA Certified for CSA C22.2 std 100 and std 14 for operation up to 40° C only



Warranty policy

The Cummins Onan limited warranty covers virtually everything except routine maintenance for the first five years that you own your generator set, or the first 1,000 hours of operation, whichever comes first. In addition, it includes a free 90-day adjustment policy, which provides that Cummins Inc. will make minor adjustments to your new generator set during the first three months you own it - free of charge!

Travel time repair allowance: In addition to the 5-year, 1000-hour warranty, a travel time repair allowance of 2.5 hours and mileage cost up to 100 miles included for the first 2 years.

WARNING:

Do not use this generator set on a boat. Such use may violate U.S. Coast Guard regulations, and can result in severe personal injury or death from fire, explosion, electrocution, or carbon monoxide poisoning.

WARNING:

Back feed to a utility system can cause electrocution and/or property damage. Do not connect to any building electrical except through an approved device or after building main

After sale support

Largest distributor/dealer support network
 Cummins Onan generator sets are supported by the largest and best trained worldwide certified distributor/dealer network in the industry. This network of knowledgeable Cummins Onan distributor/dealers will help you select and install the right generator set and accessories to meet the requirements of your specific application. This same network offers a complete selection of commonly used generator set maintenance parts, accessories and products plus manuals and specification sheets. Plus, they can answer your questions regarding proper operation, maintenance schedules and more.

Manuals: Operation and installation manuals ship with the generator set. To obtain additional copies or other manuals for this model, see your Cummins Onan distributor/dealer and request the following manual numbers: Operation (943-0102), Installation (943-0102), Parts (943-0203), Service (943-0502).

To easily locate the nearest Cummins Onan distributor/dealer in your area, or for more information, contact us at 1-800-888-6626 (or 763-574-5000), or visit www.cumminsonan.com.

Contact your distributor/dealer for more information

Cummins **Onan**

Cummins Power Generation
1400 73rd Ave. NE
Minneapolis, MN 55432 USA
Phone 1 763 574 5000
Toll-free 1 800 888 6626
Fax 1 763 574 5298
Email www.cumminsonan.com/contact
www.cumminsonan.com

